

MULTOS Roadmap

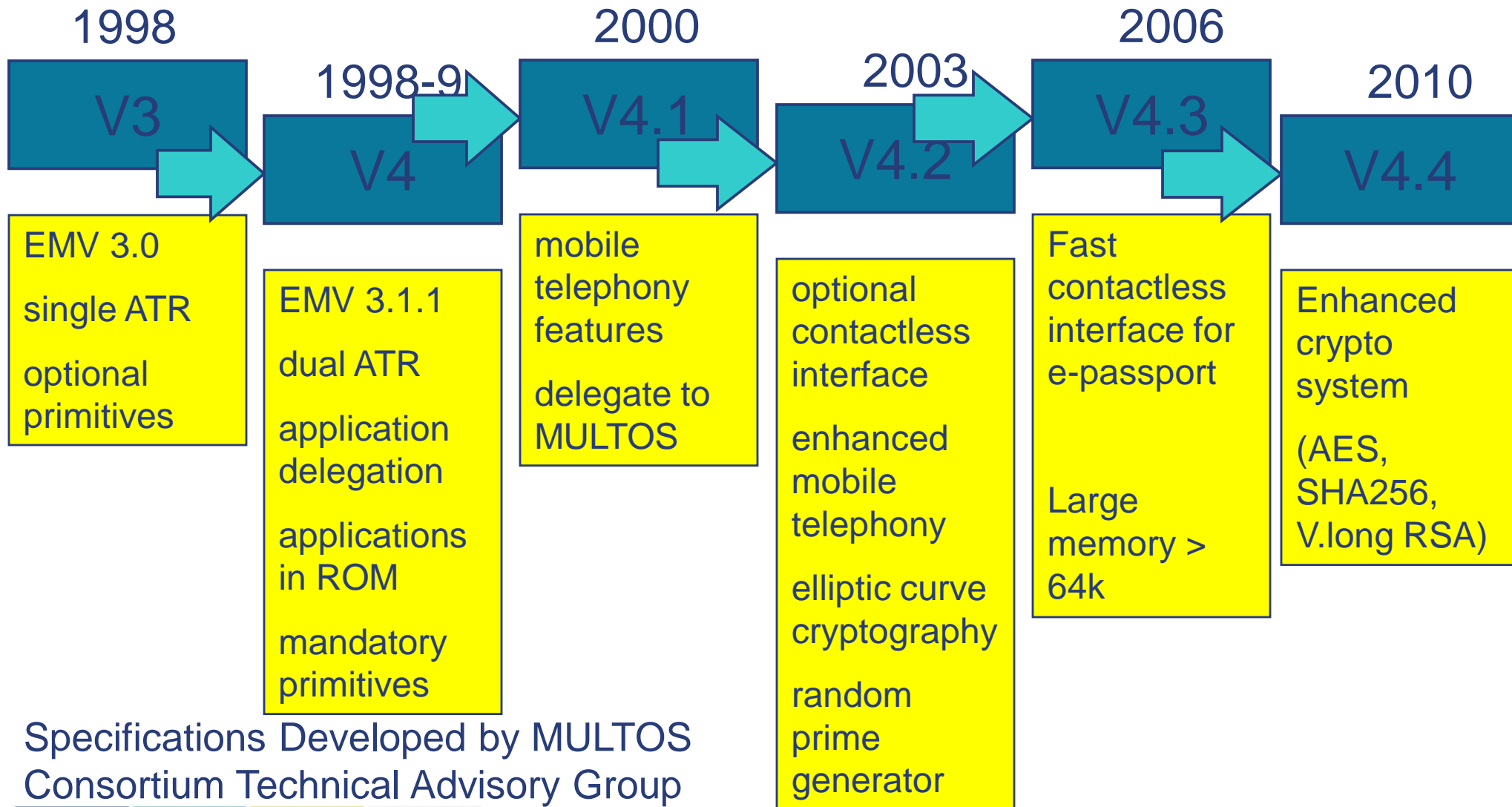

12 Years of MULTOS Specifications



Specifications Developed by MULTOS Consortium Technical Advisory Group



MULTOS 4.4 Objectives

- Upgrade MULTOS Security Scheme
 - First 'upgrade' since MULTOS was introduced
 - but **still** backwards compatible
- Improved key strength & algorithms
 - RSA key lengths beyond 1024-bit, 2048-bit for certificates
 - AES for encryption of Applications
 - introduce SHA-256 for Application Signature & certificates
- Flexible implementation / transition for KMA and Application Providers
 - does not force anyone to migrate... both schemes are supported at the same time.

MULTOS Products

coming soon

 = Dual interface / Contactless

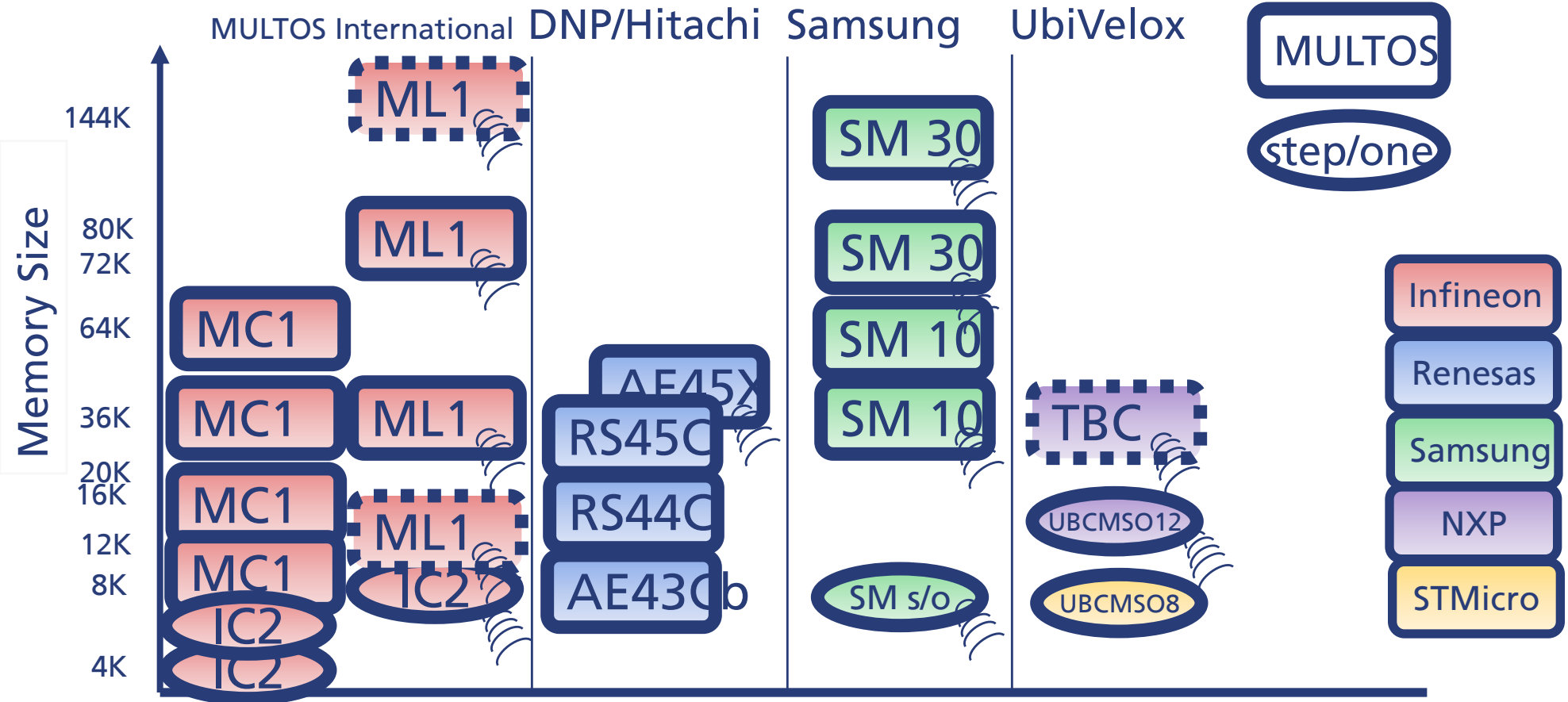

New MULTOS Platforms

- Multos International
 - MC1/ML1 platform – ONE OS for contact and contactless, 8k through to 80k (and 144k soon)
- DNP / Hitachi
 - RS4 next generation chip platform from Renesas
 - faster, higher security, cheaper
- Samsung SDS
 - SM30E R1 – new ePassport platform CC EAL4+
- UbiVelox
 - new range of MULTOS platforms, contact & dual interface.
Coming late 2010



MULTOS Applications

- VISA payWave application: qVSDC
 - latest specification for contact and contactless payments
 - configurable to do DPA too (or online security)
 - currently being type Approved by VISA
 - expected to be Soon Now!
- “non-branded” EMV application
 - configurable, customisable EMV for domestic or private payment networks
 - based on EMV with many flexible features

COMING SOON!

MULTOS Applications

- New ISO Files application
 - may be used to deliver many 'standard' smart card applications that are based on ISO file structure and file permissions such as PIN and MAC authentication
- New PKI application
 - with middleware to integrate into application solutions
- ICAO LDS (for ePassport)
 - supports BAC and EAC with Elliptic Curve

**COMING LATER
IN 2010!**

MULTOS Roadmap

- Consortium is driving MULTOS forward, in line with customer needs
 - incremental changes
 - backwards compatibility
 - protecting customer investments
- Platforms & Applications to be best in class for customer needs
 - Performance, value, long term lower total cost of ownership

MULTOS World Series Dubai

